

XGS-PON ONU SFP+ Optical Transceiver

Product Features

- Support XGS-PON 20km application
- Single fiber bi-directional data links with asymmetric 9.953Gbps Tx and 9.953Gbps Rx
- 1270nm burst-mode transmitter with DFB laser
- 1577nm continuous-mode receiver with APD-TIA
- 2-wire interface for integrated digital diagnostic Monitoring
- Transmitter state indication (TX_SD) and Receiver state indication (RX_LOS)
- SFP+ package with SC/UPC or SC/APC receptacle optical interface
- Single +3.3V power supply
- Operating case temperature: -40~85°C Industrial temperature
- RoHS compliance, and Class 1 laser safety

Operating Conditions

Parameter	Unit	Min.	Typical	Max.
Storage Temperature	°C	-40		85
Operating Case Temp	°C	-40		85
Power Supply Voltage	V	3.135	3.3	3.465
Supply Current	mA			450
Bit Rate for Tx	Gbps		9.953	
Bit Rate for Rx	Gbps		9.953	

Characteristics

All performance is specified at whole working temperature and conditions

Parameter	Unit	Min.	Typical	Max.
Transmitter				
TX Central Wavelength	nm	1260	1270	1280
Spectral Width (-20dB)	nm			1
Side Mode Suppression Mode (SMSR)	dB	30		
Mean Launched Power	dBm	4		9
Mean Launched Power (TX Off)	dBm			-45
Extinction Ratio	dB	6		
Optical Return Loss Tolerance	dB	-15		
Transmitter and dispersion Penalty	dB			2
Transmitter Mask (PRBS2 ³¹ -1@9.953G)	Compliant With ITU-T G.9807.1			
Receiver				
Receive Wavelength	nm	1575	1577	1580
Sensitivity (PRBS2 ³¹ -1@9.953G, ER=6, BER<10 ⁻³)	dBm			-28.5
Overload	dBm	-8		
SD Assert Level	dBm			-30
SD De-assert Level	dBm	-39		
SD Hysteresis	dB	0.5		5
Electrical Interface Characteristics				
Data Input Swing Differential/TX	mV	200		1000
Data Output Swing Differential/RX	mV	300		850
Data Differential Impedance	Ω	90	100	110
LVTTTL Output High	V	2.4		V _{CC}
LVTTTL Output Low	V	0		0.4
LVTTTL Input High	V	2.0		V _{CC} +0.3
LVTTTL Input Low	V	0		0.8
Timing Characteristics				
Turn On Time at Burst mode (T _{ON})	ns			128.6
Turn Off Time at Burst mode (T _{OFF})	ns			128.6
TX-SD Assert Time (T _{TXSD_ON})	ns			200
TX-SD De-assert Time (T _{TXSD_OFF})	ns			200
RX-LOS Assert Time (T _{LOSA})	us			100
RX-LOS De-assert Time (T _{LOSD})	us			100

Burst Mode Transmitter Timing

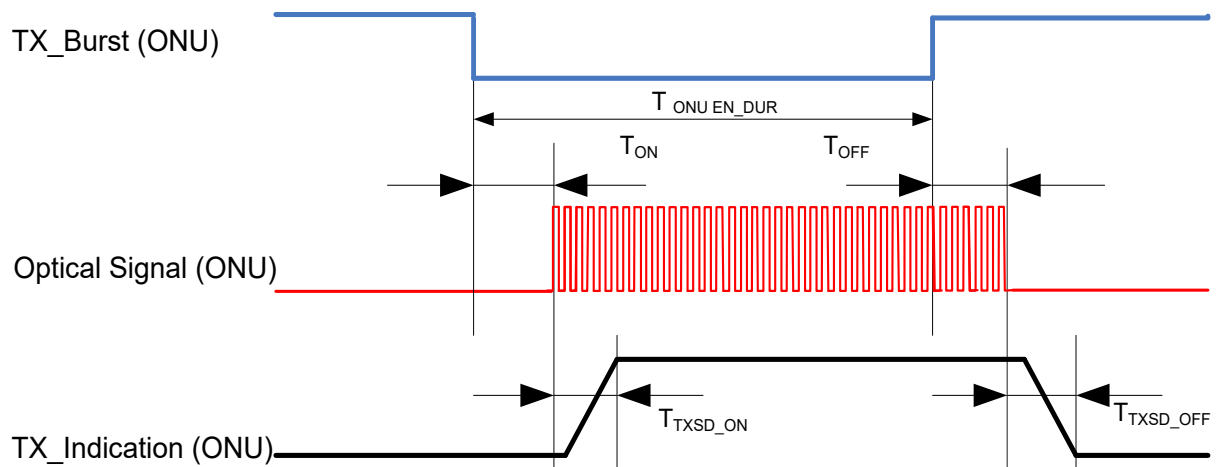

Burst Mode Transmitter Timing

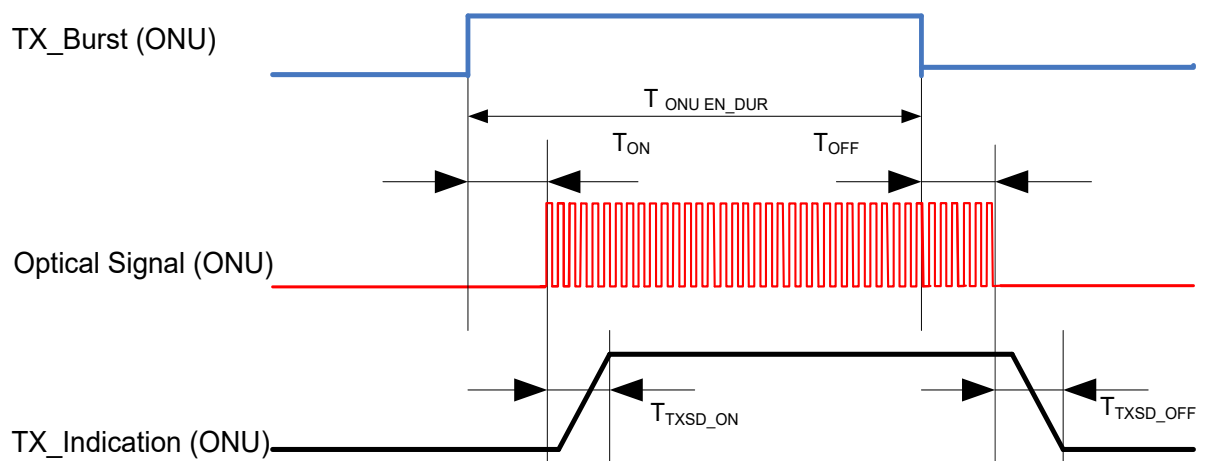

PIN Definition

Pin No.	Symbol	Level / Logic	Description
1	VeeT		Module Transmitter Ground
2	Tx_Fault	LVTTTL-O	Module Transmitter Fault
3	Tx_Burst	LVTTTL-I	Active low for transmitter on
4	SDA	LVTTTL-I	2-Wire Serial Interface Data Line
5	SCL	LVTTTL-I/O	2-Wire Serial Interface Clock
6	MOD_ABS	LVTTTL-O	Module Absent, connected to ground in the module
7	TX_SD	LVTTTL-O	Tx Signal Detect, active high when transmitter on
8	RX_LOS	LVTTTL-O	Loss of Receiver Signal Indication
9	TX_PWDN	LVTTTL-I	Power saving of Tx side, On/off time less than 1ms, active low to active Tx power saving. if this feature will not be used, main board connection should be NC
10	VeeR		Module Receiver Ground
11	VeeR		Module Receiver Ground
12	RD-	CML-O	Receiver Inverted Data Output
13	RD+	CML-O	Receiver Non-Inverted Data Output
14	VeeR		Module Receiver Ground
15	VccR		Module Receiver 3.3V Supply
16	VccT		Module Transmitter 3.3V Supply
17	VeeT		Module Transmitter Ground
18	TD+	LVPECL-I	Transmitter Non-Inverted Data Input
19	TD-	LVPECL-I	Transmitter Inverted Data Input
20	VeeT		Module Transmitter Ground

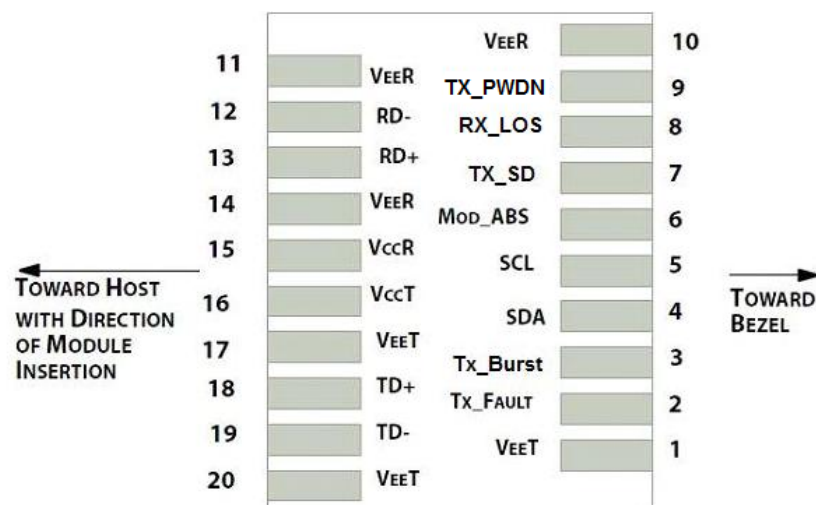

Typical Interface Circuit

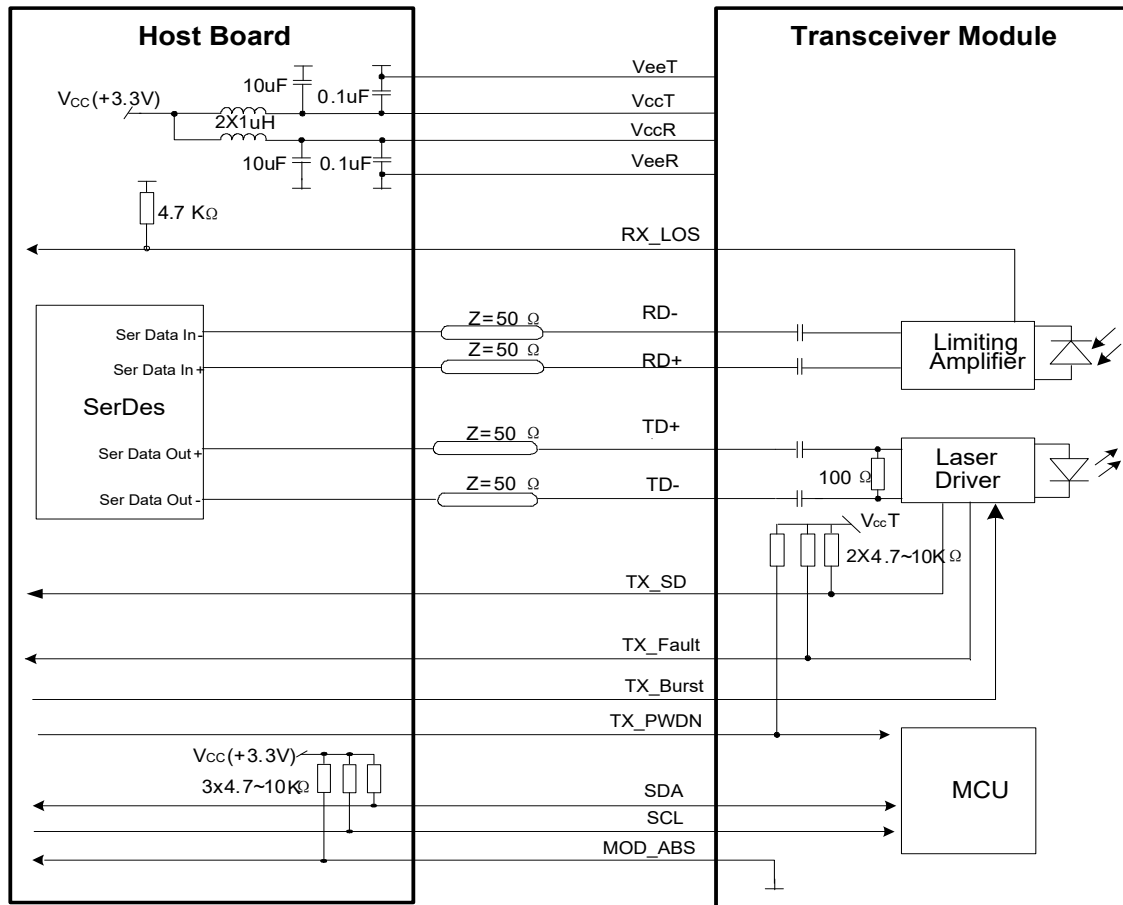

Mechanical Diagram

For detail mechanical information, please refer to the related document of SFF-8432

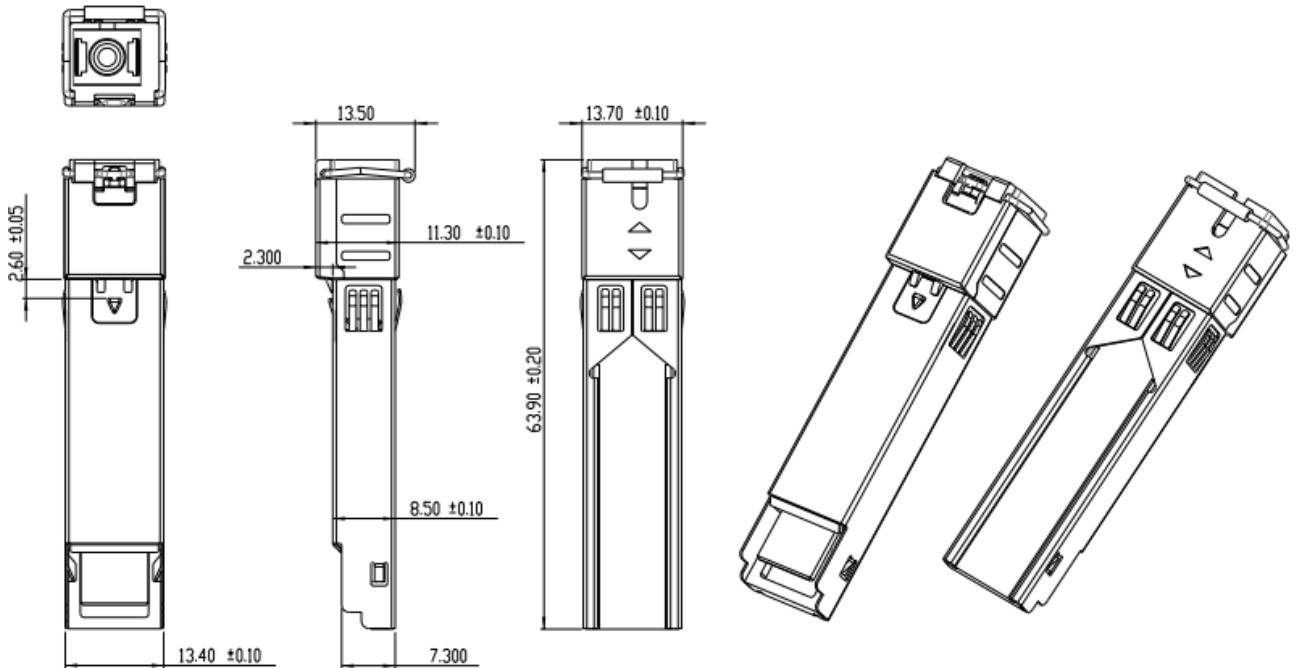

EEPROM Memory Map

The digital diagnostic memory map specific data field define as following. For detail EEPROM information, please refer to the related document of SFF-8472

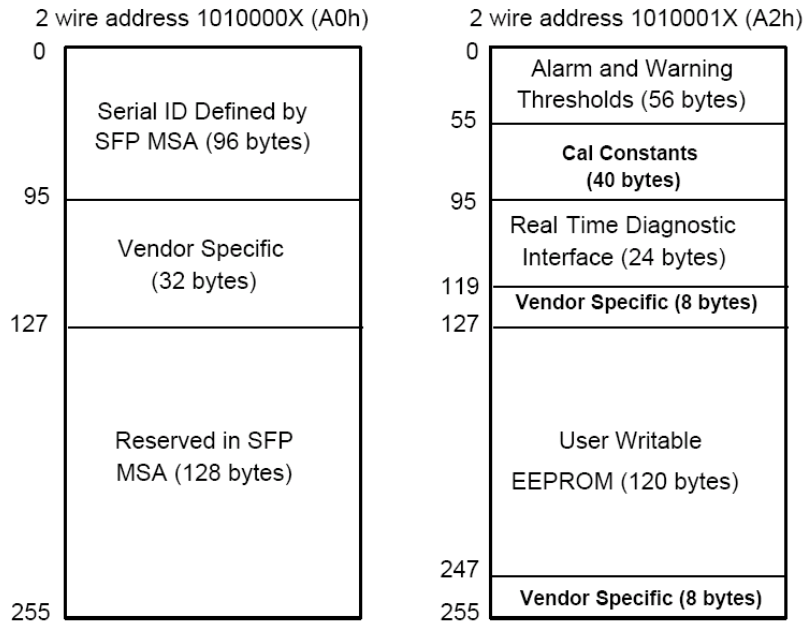

ESD

The SFP+ module and host SFI contacts (High Speed Contacts) shall withstand 1kV electrostatic discharge based on Human Body Model and all host contacts with exception of the SFI contacts (High Speed Contacts) shall withstand 2kV electrostatic discharge based on Human Body Model. The SFP+ module shall meet ESD requirements given in EN61000-4-2, criterion B test specification such that units are subjected to 15kV air discharges during operation and 8kV direct contact discharges to the case per section 2.9 in SFF-8431 REV4.1. However, normal ESD precautions are still required during the handling of this module. This transceiver is shipped in ESD protective packaging. It should be removed from the packaging and handled only in an ESD protected environment.

Laser Safety

This is a Class 1 Laser Product according to IEC 60825-1:2007. This product complies with 21 CFR 1040.10 and 1040.11 except for deviations pursuant to Laser Notice No. 50, dated (June 24, 2007).

Ordering Information

Ordering P/Ns	Description
D227RR-SSHHC	XGS-PON ONU, 20km, Tx 1270nm 9.953G, Rx 1577nm 9.953G, TX_Burst signal low active transmitter on, SFP+ form-factor, SC/UPC receptacle connector, -40~85°C Industrial temperature

Contact Us**International Sales**

Email: Sales@broadex-tech.co.uk

Tel: +44-1506-426021

Mobile: +44-7968-854124

China Sales

Tel: +86-573-82585881

Email: Sales@broadex-tech.com

Copyright © 2021 Broadex Technologies. All rights reserved